

REVISIONS				
ZONE	REV	DESCRIPTION	DATE	APPROVED
	0	RELEASED FOR PRODUCTION	9/28/2017	Lou Nielsen

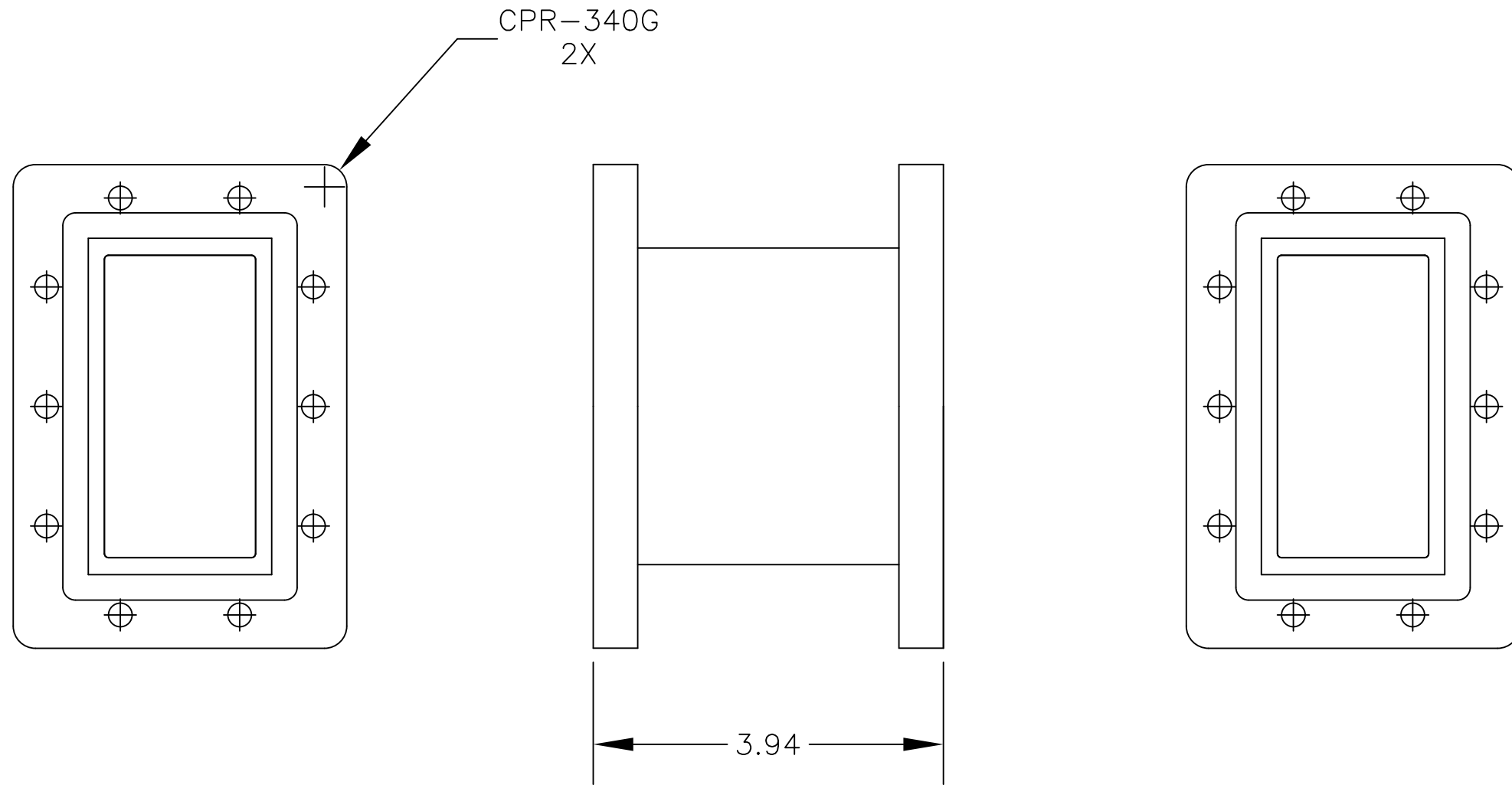

QTY	PART NUMBER OR IDENTIFICATION	DESCRIPTION	ITEM NO.
		CML Engineering, Inc. 2020 Ridgecrest Place, Escondido, CA 92029 TEL: 760-432-8490 FAX: 760-432-8350	
		OUTLINE: MODEL 1015-03	
	FINISH: 63 U INCH OR BETTER EDGES: BREAK EDGES 1/32 R MAX.	SIZE B CAGE CODE 1ZLK8 DWG NO. 1015-03-0000	REV 0
	MATERIAL: REFERENCE	SCALE NONE Drawn By: L/JN Date: 9/28/2017	SHEET 1 of 1

TOLERANCES
(UNLESS OTHERWISE SPECIFIED)

DECIMALS: 1 PLACE +/- .050
2 PLACE +/- .020
3 PLACE +/- .005

FRACTIONS: +/- 1/16
ANGLES: +/- 1/2 DEGREE

CML Engineering, Inc.

2020 Ridgecrest Place, Escondido, CA 92029 TEL: 760-432-8490 FAX: 760-432-8350

OUTLINE: MODEL 1015-03

FINISH: 63 U INCH OR BETTER
EDGES: BREAK EDGES 1/32 R MAX.

SIZE B CAGE CODE 1ZLK8 DWG NO. 1015-03-0000

REV 0

MATERIAL: REFERENCE SCALE NONE Drawn By: L/JN Date: 9/28/2017 SHEET 1 of 1