

REVISIONS				
ZONE	REV	DESCRIPTION	DATE	APPROVED
	0	RELEASED FOR PRODUCTION	5/29/2004	Lou Nielsen

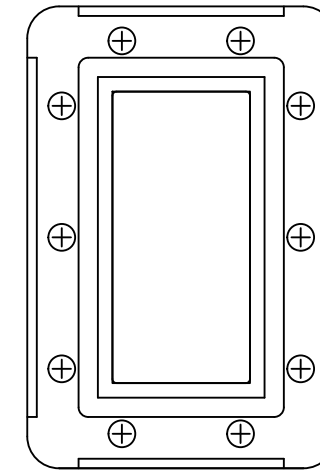

CPR-284G FLANGE, 2PL.

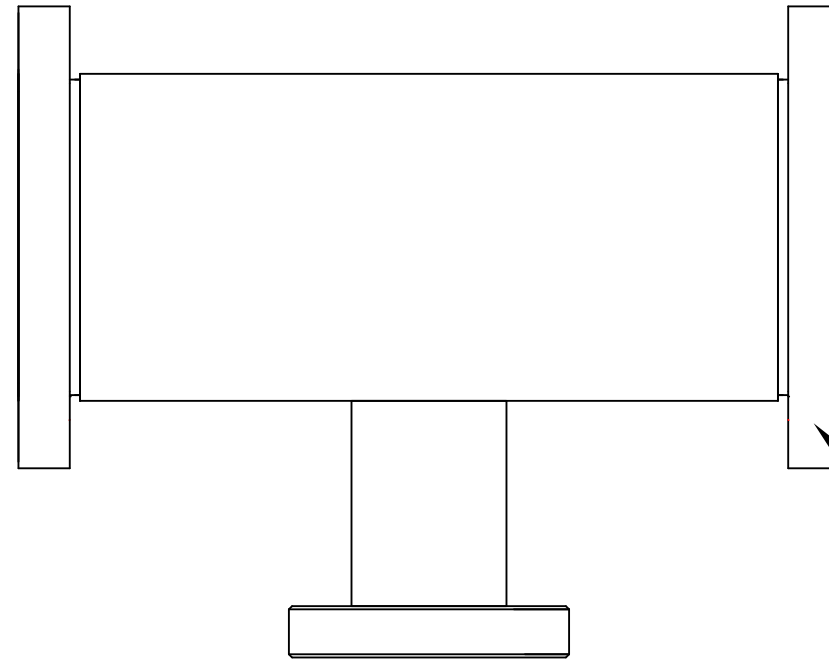
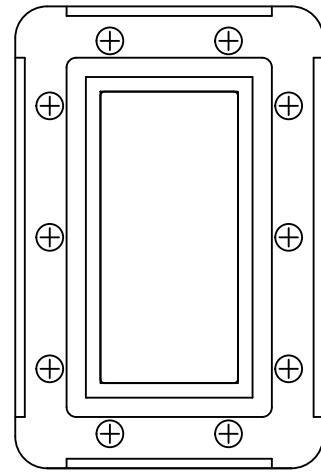
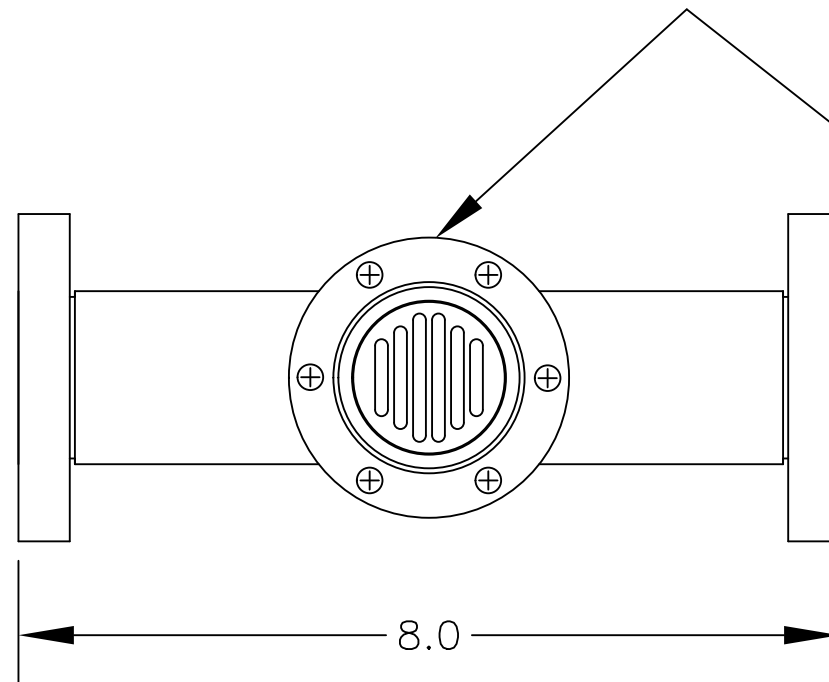

2-3/4"  
NON-ROTATABLE  
CONFLAT  
FLANGE

TOLERANCES  
(UNLESS OTHERWISE SPECIFIED)

DECIMALS: 1 PLACE +/- .050  
2 PLACE +/- .020  
3 PLACE +/- .005

FRACTIONS: +/- 1/16  
ANGLES: +/- 1/2 DEGREE

FINISH: 63 U INCH OR BETTER  
EDGES: BREAK EDGES 1/32 R MAX.

MATERIAL: REFERENCE

**CML Engineering, Inc.**  
2020 Ridgecrest Place, Escondido, CA 92029 TEL: 760-432-8490 FAX: 760-432-8350

**OUTLINE, MODEL 1920-01**

SIZE <b>B</b>	CAGE CODE	DWG NO. <b>1920-01-0000</b>	REV <b>0</b>
SCALE <b>NONE</b>	Drawn By: L/JN	Date: 5/23/2004	SHEET <b>1 of 1</b>