

REVISIONS				
ZONE	REV	DESCRIPTION	DATE	APPROVED
	0	RELEASED FOR PRODUCTION	12/16/99	Lou Nielsen

SLAC MALE FLANGE

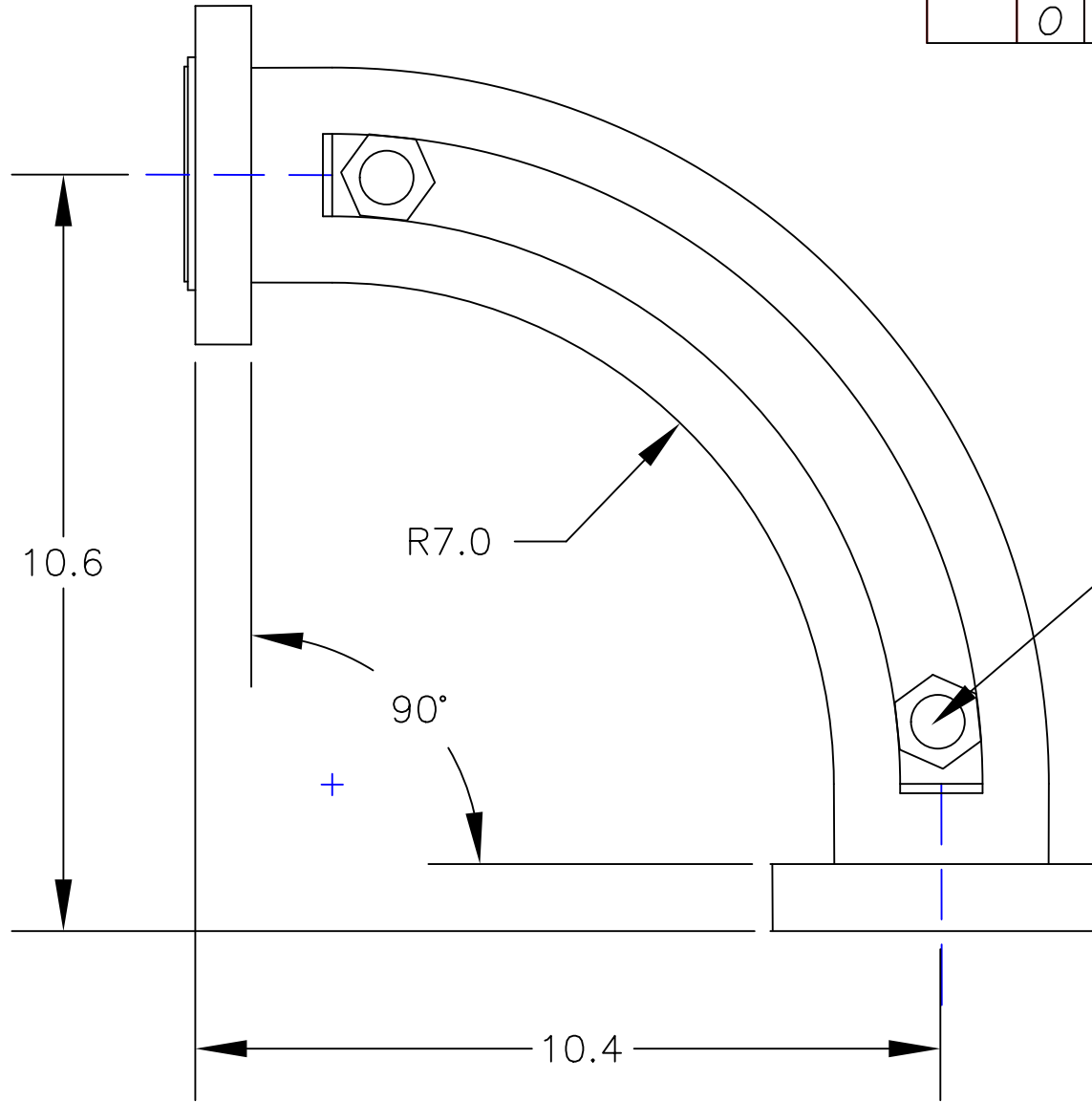
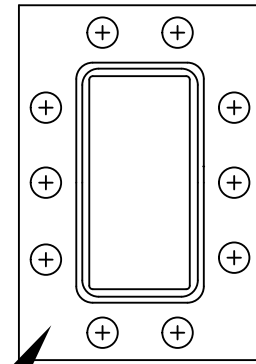

3/4" NPT FEMALE, 2PL.

SLAC FEMALE FLANGE

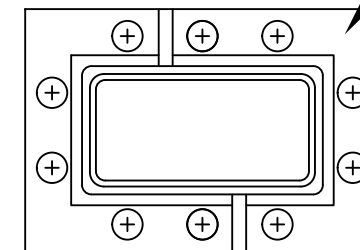

TOLERANCES
(UNLESS OTHERWISE SPECIFIED)

DECIMALS: 1 PLACE +/- .050
2 PLACE +/- .020
3 PLACE +/- .005

FRACTIONS: +/- 1/16
ANGLES: +/- 1/2 DEGREE

FINISH: 63 U INCH OR BETTER
EDGES: BREAK EDGES 1/32 R MAX.

MATERIAL: REFERENCE

CML Engineering, Inc.
2020 Ridgecrest Place, Escondido, CA 92029 TEL: 760-432-8490 FAX: 760-432-8350

MODEL 1405 H-PLANE BEND

SIZE B	CAGE CODE	DWG NO. 1405 - 0000	REV 0
SCALE NONE	Drawn By: L/JN	Date: 12/15/99	SHEET 1 of 1