

REVISIONS				
ZONE	REV	DESCRIPTION	DATE	APPROVED
	0	PRELIMINARY	12/29/2010	Lou Nielsen

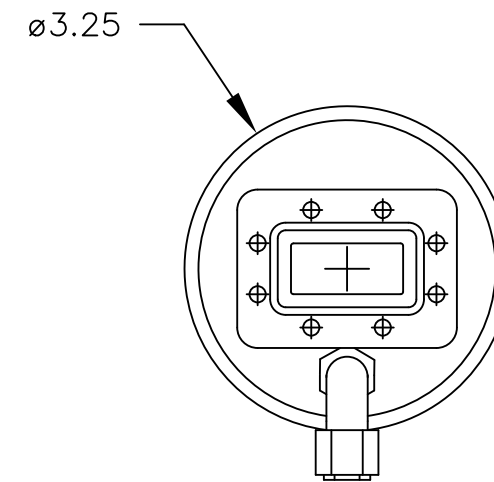
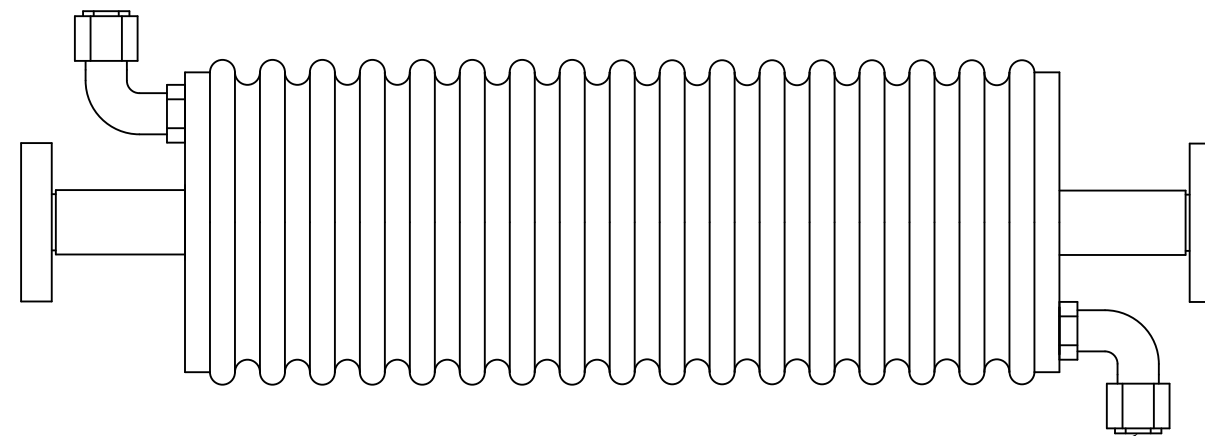
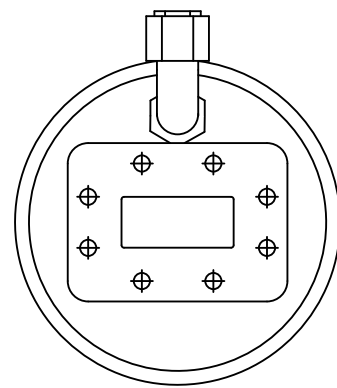
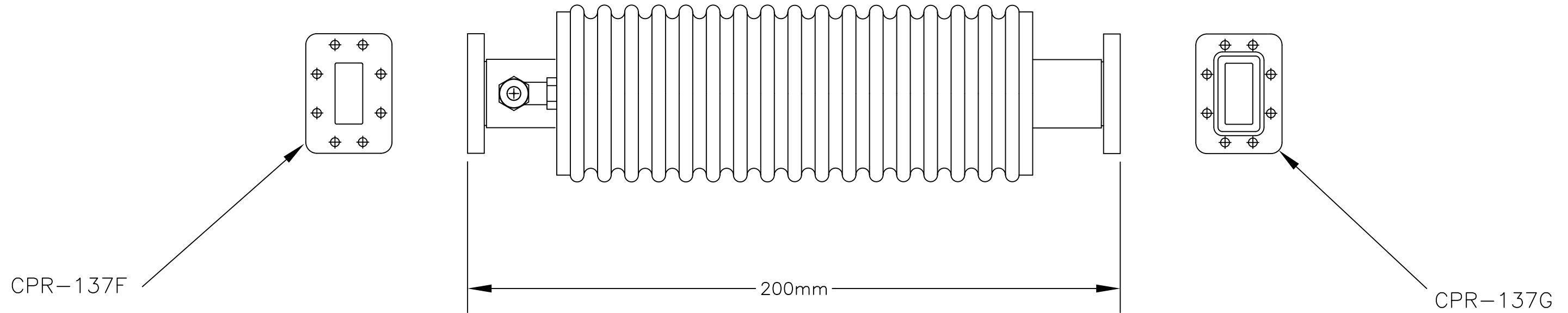

3/8" SWAGELOCK, 2X

<p>TOLERANCES (UNLESS OTHERWISE SPECIFIED)</p> <p>DECIMALS: 1 PLACE +/- .050 2 PLACE +/- .020 3 PLACE +/- .005</p> <p>FRACTIONS: +/- 1/16 ANGLES: +/- 1/2 DEGREE</p> <p>FINISH: 63 U INCH OR BETTER EDGES: BREAK EDGES 1/32 R MAX.</p> <p>MATERIAL: REFERENCE</p>		<p><b>CML Engineering, Inc.</b> 2020 Ridgecrest Place, Escondido, CA 92029 TEL: 760-432-8490 FAX: 760-432-8350</p> <p><b>OUTLINE, MODEL 1840-00</b></p>	
SIZE <b>B</b>	CAGE CODE	DWG NO. <b>1840-00-0000</b>	REV <b>0</b>
SCALE <b>NONE</b>	Drawn By: L/JN Date: 12/23/2010		SHEET <b>1 of 1</b>