

REVISIONS				
ZONE	REV	DESCRIPTION	DATE	APPROVED
	0	PRELIMINARY	12/29/2009	Lou Nielsen

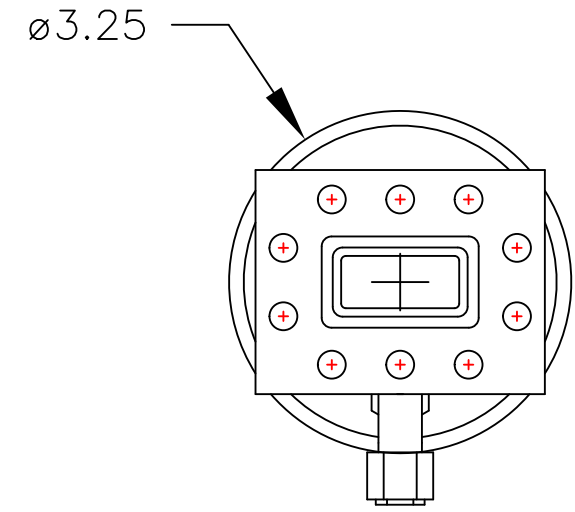
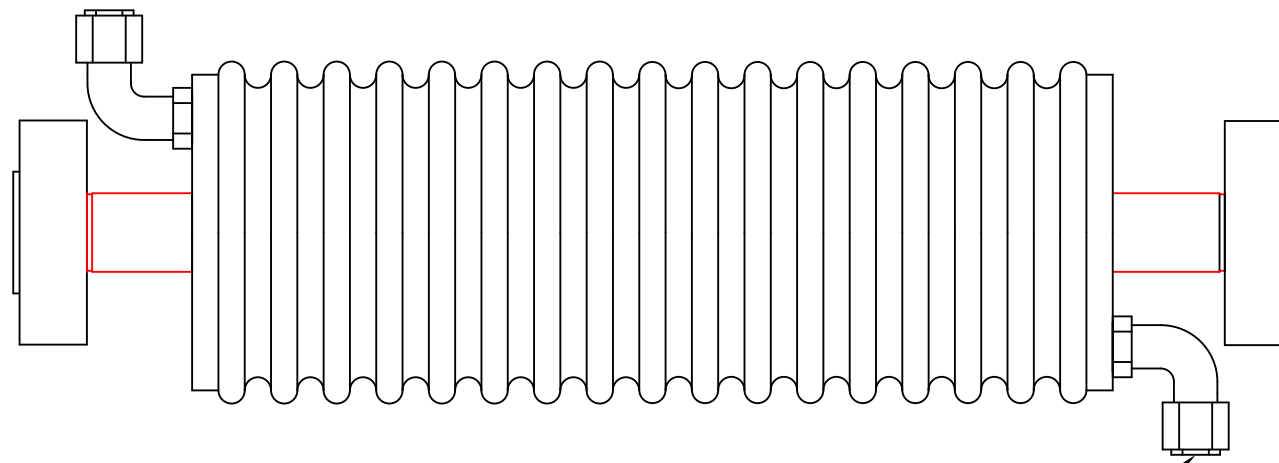
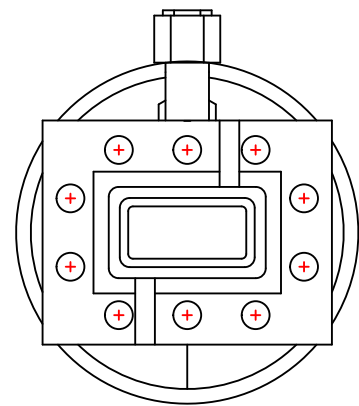
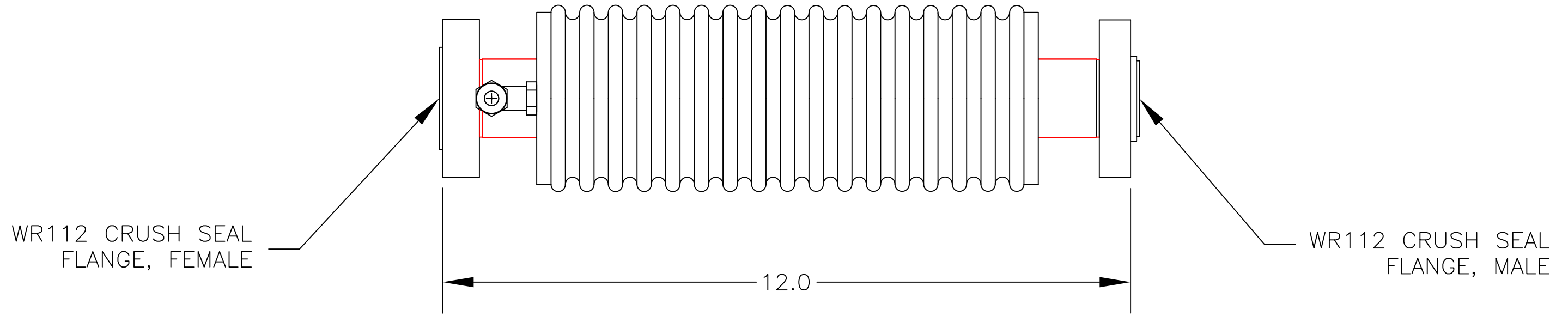

TOLERANCES (UNLESS OTHERWISE SPECIFIED) DECIMALS: 1 PLACE +/- .050 2 PLACE +/- .020 3 PLACE +/- .005 FRACTIONS: +/- 1/16 ANGLES: +/- 1/2 DEGREE FINISH: 63 U INCH OR BETTER EDGES: BREAK EDGES 1/32 R MAX. MATERIAL: REFERENCE		CML Engineering, Inc. 2020 Ridgecrest Place, Escondido, CA 92029 TEL: 760-432-8490 FAX: 760-432-8350 OUTLINE, MODEL 1845-00		
SIZE B	CAGE CODE	DWG NO. 1845-00-0000	REV 0	
SCALE NONE	Drawn By: L/JN	Date: 12/23/2007	SHEET 1 of 1	