

REVISIONS				
ZONE	REV	DESCRIPTION	DATE	APPROVED
	0	RELEASED FOR PRODUCTION	8/9/2002	Lou Nielsen

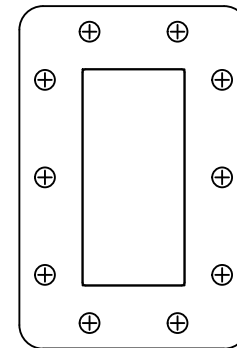
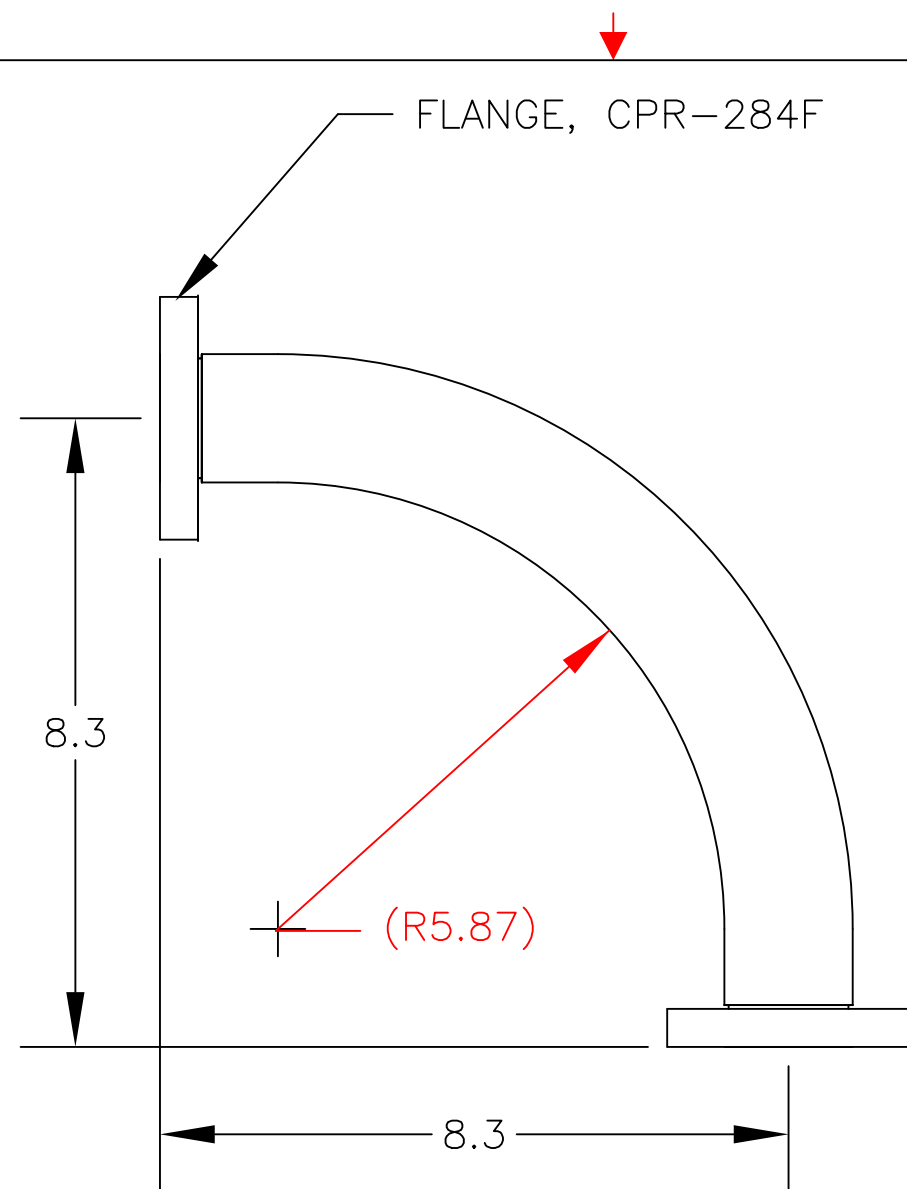
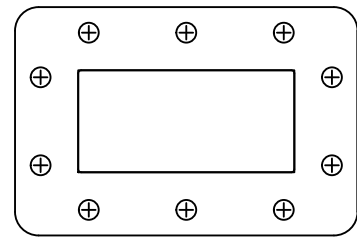

QTY REQ'D	PART NUMBER OR IDENTIFICATION	DESCRIPTION		ITEM NO.
		<b>CML Engineering, Inc.</b>		
		2020 Ridgecrest Place, Escondido, CA 92029 TEL: 760-432-8490 FAX: 760-432-8350		
		<b>OUTLINE, MODEL 1220-02</b>		
TOLERANCES (UNLESS OTHERWISE SPECIFIED)  DECIMALS: 1 PLACE +/- .050 2 PLACE +/- .020 3 PLACE +/- .005  FRACTIONS: +/- 1/16 ANGLES: +/- 1/2 DEGREE		SIZE B	CAGE CODE	DWG NO. 1220-02-0000
FINISH: 63 U INCH OR BETTER EDGES: BREAK EDGES 1/32 R MAX.				REV 0
MATERIAL: REFERENCE		SCALE NONE	Drawn By: L/JN Date: 12/15/99	SHEET 1 of 1