

REVISIONS				
ZONE	REV	DESCRIPTION	DATE	APPROVED
	0	RELEASED FOR PRODUCTION	6/14/2001	Lou Nielsen

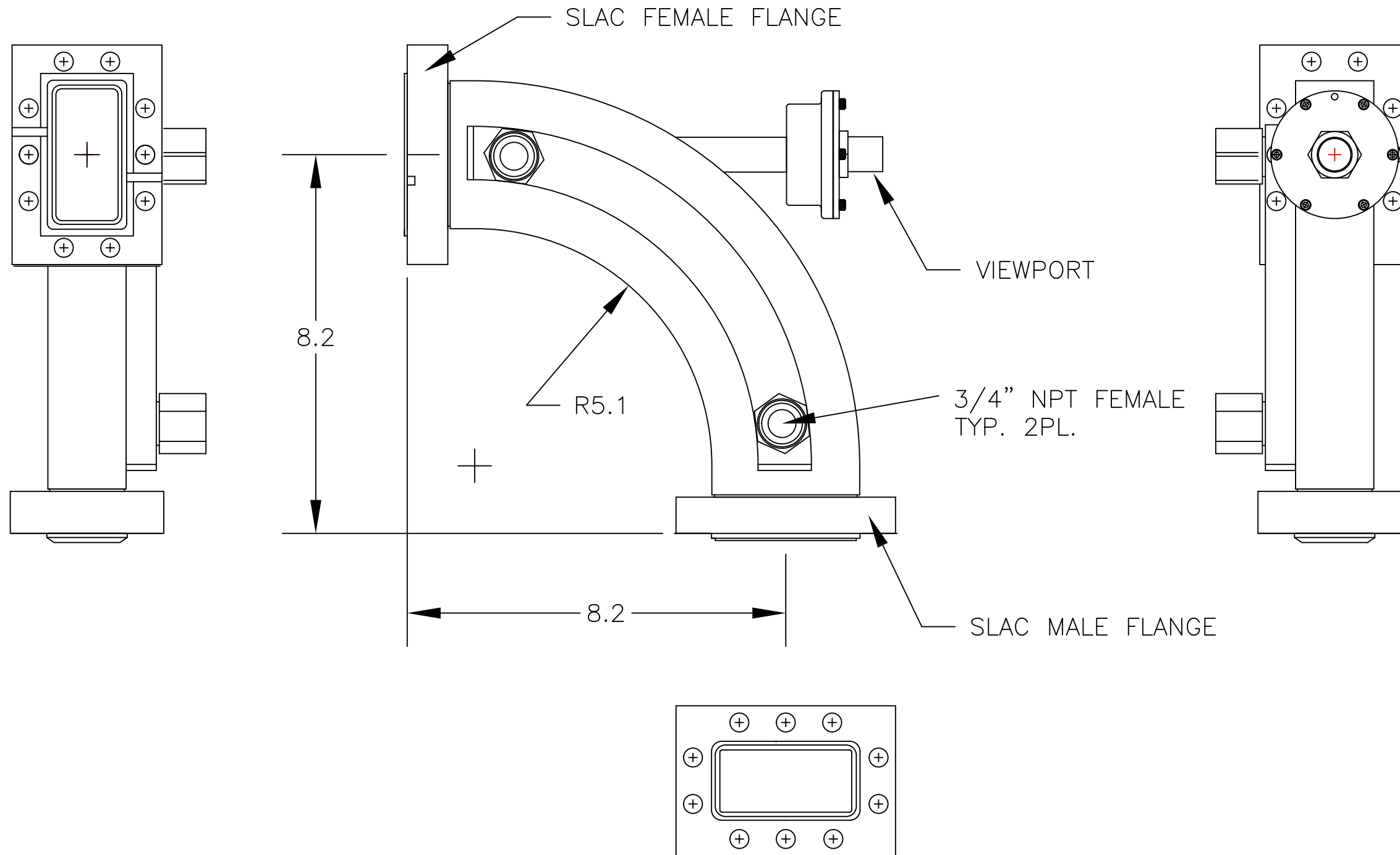

TOLERANCES
(UNLESS OTHERWISE SPECIFIED)

DECIMALS:
 1 PLACE ± .050
 2 PLACE ± .020
 3 PLACE ± .005

FRACTIONS: ± 1/16
 ANGLES: ± 1/2 DEGREE

CML Engineering, Inc.
 2020 Ridgecrest Place, Escondido, CA 92029 TEL: 760-432-8490 FAX: 760-432-8350

OUTLINE, MODEL 1407			
SIZE B	CAGE CODE	DWG NO. 1407 - 0000	REV 0
SCALE NONE	Drawn By: L/JN	Date: 6/12/2001	SHEET 1 of 1